

DIRECTIONAL CONTROL VALVES - proof II 2 GD, Ex db IIC T5 Gb, Ex tb IIIC T5 Db IP 66/67

HD5-EX/50

150 l/min 35 MPa (350 bar)

1 DESCRIPTION

HD5-EX/50 Ex proof electrically are pilot operated 4 way valves of size ISO 05 with mounting surface according to Cetop 4.2-4 P05-320
 Characteristics of the Ex proof, electrically operated, pilot valve type HD3-EX/30 are described on Aidro table HD3-EX/30.

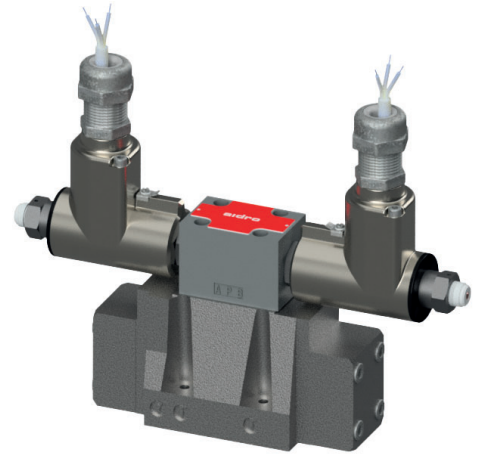

2 ORDERING CODE

(1)	(2)	(3)	(4)	(5)	(6)	(7)	(8)
HD5	-	EX	-	-	-	-	50

(1) HD5: 4-way directional control valve Cetop 05- Pressure 35 MPa (350 bar)

(2) Variants:

- EX: electrically controlled, EX Proof ATEX
- HH: hydraulically piloted (main body)

(3) Spool type:

- number is the main spool type
- letter is the solenoid or spring arrangement:
 - C : 2 solenoids, spool is spring centered (3 position)
 - LL : 1 solenoid (a), spool is spring/hydr. offset (2 position, end to end)
 - ML: 1 solenoid (a), spool is spring offset (2 position, middle to end)
 - LM: 1 solenoid (a), spool is spring offset (2 position, end to middle)
- b: only for versions LL, MI, LM see also functional symbols

(4) Location of X and Y ports.

- no designation: standard, according to CETOP 4.2-4 P05-320
- R05: according to CETOP 4.2-4R05-320 and ISO/ CD 4401-05

(5) Code reserved for options and variants (see)

- C: adjustable limits for main spool stroke
- D: double flow control valve to adjust shifting speed
- G: adjustable limits and adjustable shifting speed

(6) Pilot and drain arrangement

- no designation: internal pilot and external drain (standard)
- I : internal pilot and internal drain
- E: external pilot and external drain

(7) Electric voltage and solenoid coils

- 012C : coils for V12DC
 - 024C : coils for V24DC
 - 115A : coils for V110/50 - V 115/60 AC
 - 230A : coils for V220/50 - V 230/60 AC
- See also electric characteristics

(8) Design number (progressive) of the valves

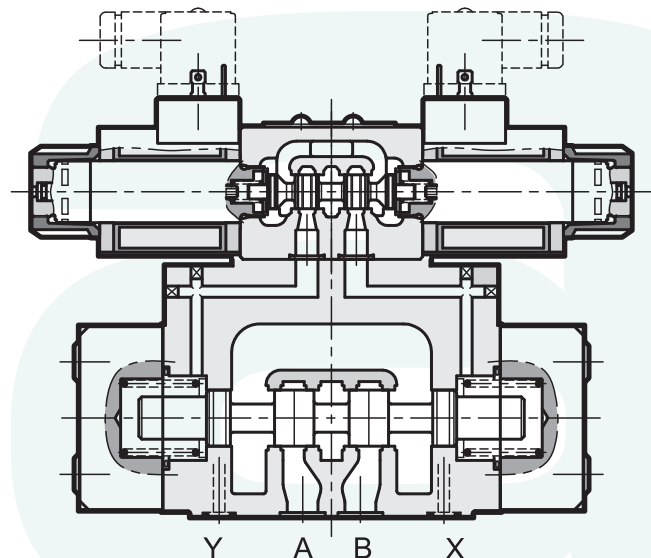
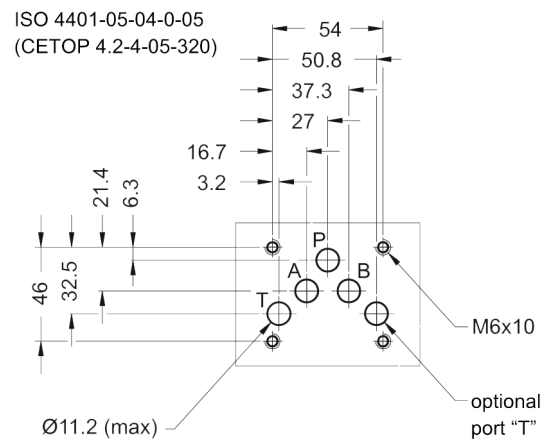

3 TECHNICAL DATA

max recommended flow (spring centering)	150 l/min	Note: When valves HD5-EX-** are made with internal pilot and internal drain ("I" configuration), ports X and Y are not used and valves can be installed on normal 05 surface mounting plates according to ISO 4401-05.
Maximum pressure (P,A,B)	32 MPa (320 bar)	
Maximum pressure at T port (internal drain)	16 MPa (160 bar)	
Maximum pressure at T port (external drain)	25 MPa (250 bar)	
Pilot pressure minimum	0,5 MPa (5 bar)	
Pilot pressure maximum recommended	20 MPa (200 bar)	
Dimensions and installation	see 6	
Mass	Approx 9,00/10,2 kg	

4 PRESSURE DROP

Δp -Q
Measured at $v = 166$ SUS (35 mm²/s) and $t = 122$ °F (50 °C)

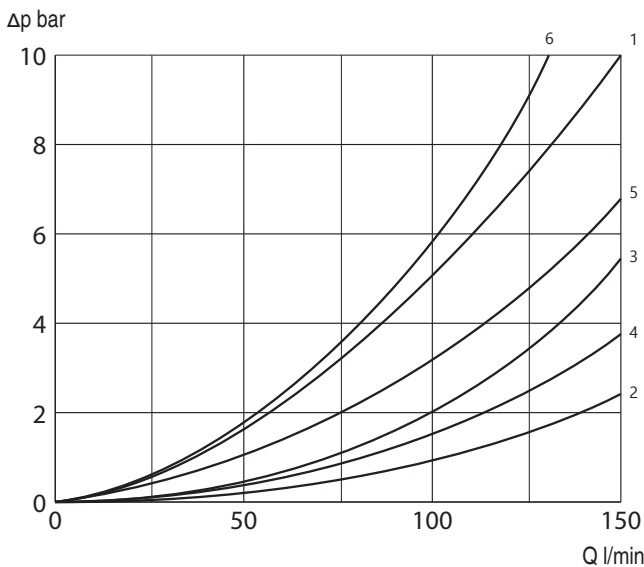

See reference table 7

5 SPOOL IDENTIFICATION AND INTERMEDIATE POSITION TRANSITORIES

Three positions with spring centering

1C		
0C		
3C		
4C		

Two positions with return spring

1LL		
0LL		
1ML		
1LLb		
0LLb		
1MLb		

Three positions with spring centering - special spools

77C		
56C		
8C		
76C		

6 INSTALLATION DIMENSIONS (mm)

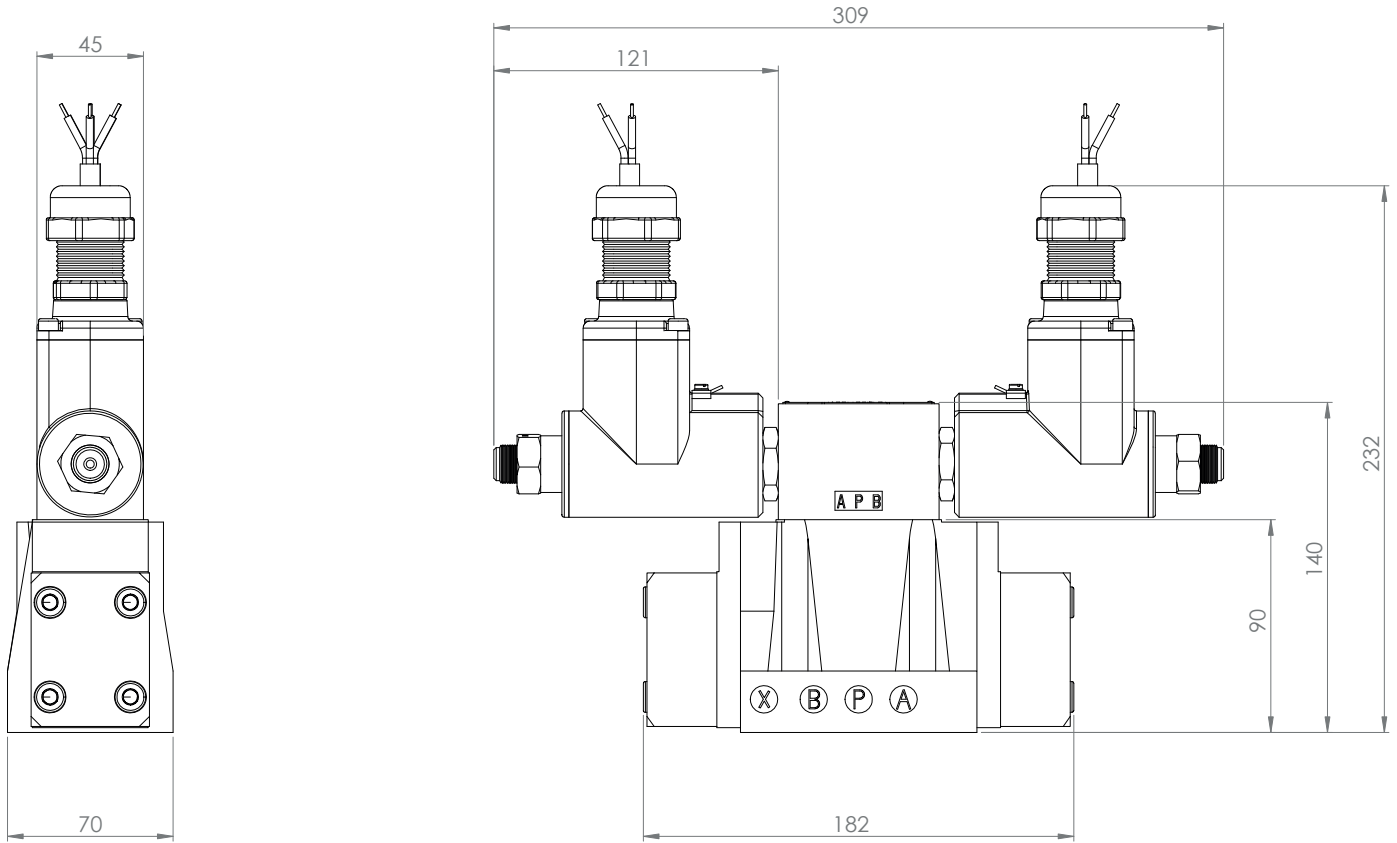

7 PRESSURE DROPS SPOOLS REFERENCE

Spool type	Spool position	Connections				
		P-A	P-B	A-T	B-T	P-T
1C	Energized	1	1	2	3	
0C	De-energized					6*
	Energized	5	5	1	2	
3C	De-energized			4*	4°	
	Energized	1	1	1	2	
4C	De-energized					6
	Energized	6	6	3	4	
1LL,0LL	De-energized	1			3	
1ML	Energized		1	2		
77C	De-energized				4	
	Energized	1	1	2	2	
56C	De-energized					6*
	Energized	6	6	4	3	
8C	De-energized	4*	4°			
	Energized	5	5	2	3	
76C	De-energized			3		
	Energized	1	1	1	3	

* A-B blocked
· B blocked
° A blocked

8 EXPLOSION PROOF SOLENOID GMA-6/HD SERIES 271 GD

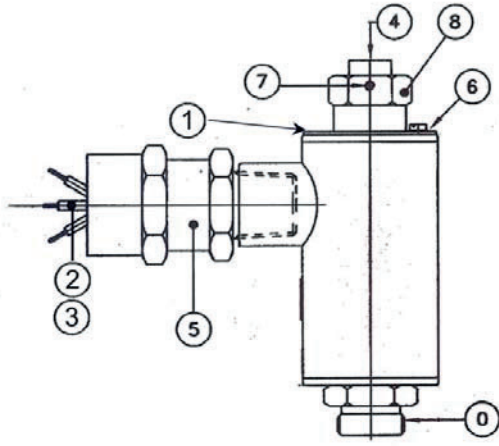

Atex Certificates :
INERIS 05ATEX0028X/02 for Gas and Dust

0: Ex proof solenoid according to ATEX 94/9/EC.

II 2GD Ex db IIC T5 Gb, Ex tb IIIC T100 °C Db IP66/67.

Solenoid outside surfaces are zinc-nickel plated, with 7µm minimum thickness

1: Solenoid label indicates supply voltage, protection class Exd, certification number by INERIS and maximum absorbed power.

2: 3-wires cable, according to CEI 20-22, of standard length of 3 m, is fastened to the coil and locked by cable gland.

3: Wires have 1,5 mm² section; earth connection wire is green-yellow.

Electric connection must be in accordance with Ex-proof norm ATEX.

4: Manual override operation is by pushing the extended pin.

5: Normalised cable gland –torque 8 Nm + 1 – device has threaded attachment ½” conical – ISO 7/1

6: Earth connection screw

7: Threaded plug (socket hexagon 1,5 mm)to lock the retaining coil nut □

8: Nut for retaining the coil –torque 6 Nm + 1 – hexagon 24 mm.

Conformity of unit to the norms is not granted if coil is used separately from its electromagnetic tube.

9 OPTIONS AND VARIANTS

Control of the main spool stroke: C

It is possible to introduce special stroke controls in the heads of the hydropiloted valve so as to vary the maximum spool stroke. This solution allows control of the flow rate from the pump to the actuator and from the actuator to the outlet, obtaining a double adjustable control on the actuator. Add the letter **C** to the identification code to request this device.

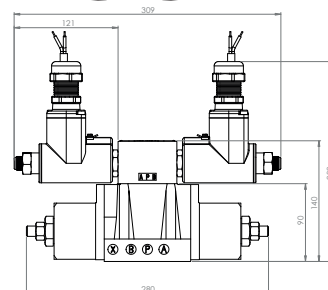

Control of the main spool shifting speed: D

By placing a double flow control valve between the pilot solenoid valve and the hydropiloted valve, the piloted flow rate can be controlled and therefore the shifting speed can be varied. Add the letter **D** to the identification code to request this device.

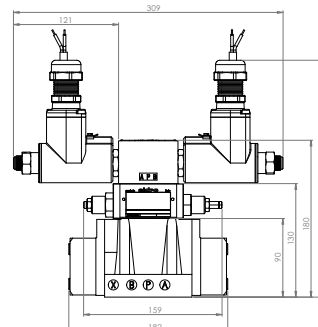

Control of the main spool stroke and shifting speed: G

It is possible to have the valve fitted with both the spool stroke device and the piloting flow rate control device. Add the letter **G** to the identification code to request this solution.

