

STACKABLE VALVES FLOW CONTROL

AM2-FX-*

30 l/min - 32 MPa (320 bar)

1 DESCRIPTION

Stackable valve CETOP 2 with meter in control (referred to the hydraulic actuator). It is possible to control the lines A, B or AB simply turning the side screws.

On demand it is possible to have also the fine control option.



2 ORDERING CODE

(1)	(2)	(3)	(4)	(5)	(6)	
AM2	-	FX	-	-	/	10

- (1) AM2: stackable valve CETOP 02- Pressure 32MPa (320bar)
- (2) FX: one-way flow control valves with meter-in control (referred to the hydraulic actuator)
- (3) Service lines where the controls operate:
 - AB: controls on A and B. Fluid flows unrestricted A1 -> A, and B1 -> B and flow is controlled from A -> A1 and B -> B1
 - A : flow is controlled from A -> A1; free on B, P and T
 - B : flow is controlled from B -> B1; free on A, P and T
- (4) Flow control characteristics for A -> A1 and B -> B1 and check valve opening pressure (Pm) for flow A1-> A and B1 -> B
 - no designation : standard control and Pm approx 0.04 MPa (0.4 bar)
 - F: fine and sensitive control
 - 4 : Pm approx 0.4 MPa (4 bar)
- (5) Code reserved for special variants (materials, seals, surface treatments etc.).
- (6) Design number (progressive) of the valves

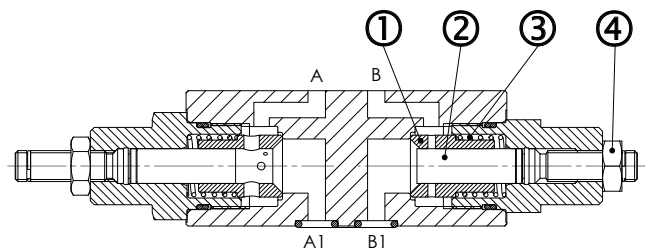
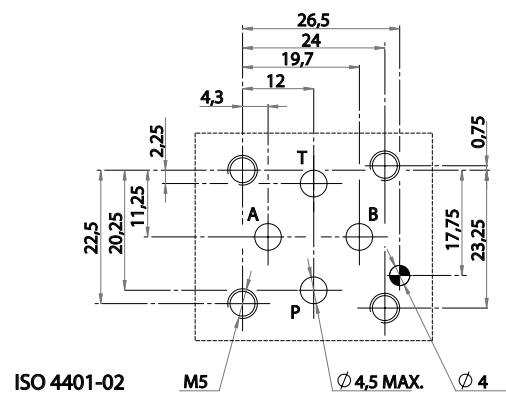

Fluid flows freely on P and T lines; on service lines A and/or B with controls, fluid flows from A-> A1 (and/or B -> B1) overcoming the force of spring acting on sleeve; fluid flows from A1 -> A (and/or B1-> B) through orifices of sleeve which is pushed against its seat; the throttling axis which is shifted by screwing it and locked by its nut, partially obstructs the control orifices, thus making the flow rate entirely dependent upon the available pressure drop.

AM2-FX-AB

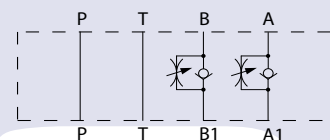

AM2-FX-A

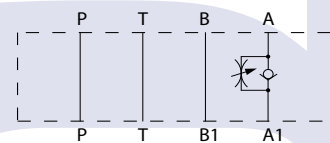

AM2-FX-B

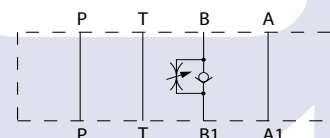

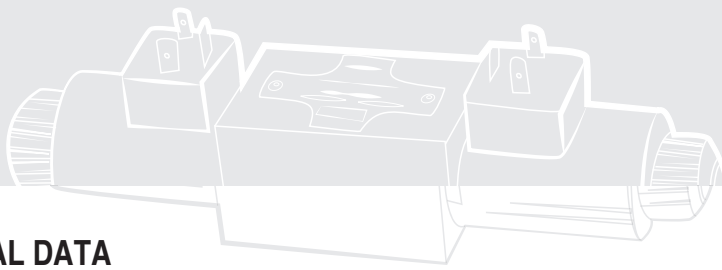

3 TECHNICAL DATA

Maximum nominal flow	32 l/min	Control of the flow: The control is made by throttling from A1 -> A (and/or B1 ->B) through variable orifices. Depending on the various sleeve/axis combination, the control adjustment is: no designation: standard, orifices area is reduced from 100% (*) to 0% with 6 complete turns of the adjustment screw F (fine and sensitive): from 100% (*) to 0% with 8 complete turns - special variant (*)100 approx: Q=0,5dm³/s (30l/min) at Δp= 1MPa (10bar)
Maximum rec. flow rate	30 l/min	
maximum nominal pressure	32 MPa (320 bar)	
Pressure drops	see 4	
installation and dimensions	see 5	
Mass	approx 0,8 kg	

4 TYPICAL DIAGRAMS

Typical Δp-Q curves for valves AM2 -FX-AB in standard configuration, with mineral oil at 36 cSt and at 50°C with throttling axis at full retraction.

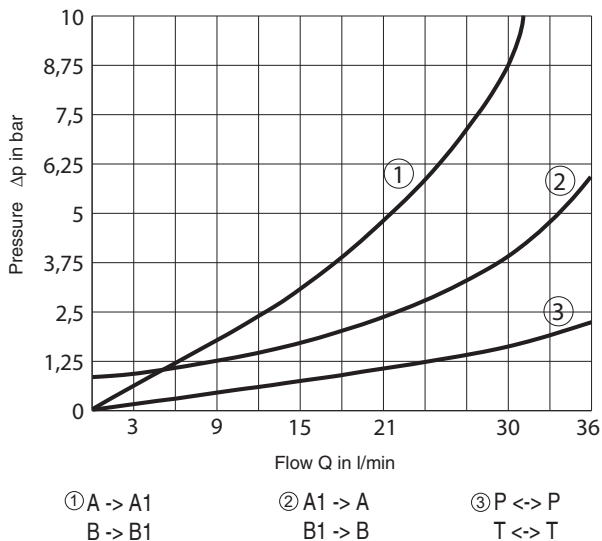

5 INSTALLATION DIMENSIONS (mm)

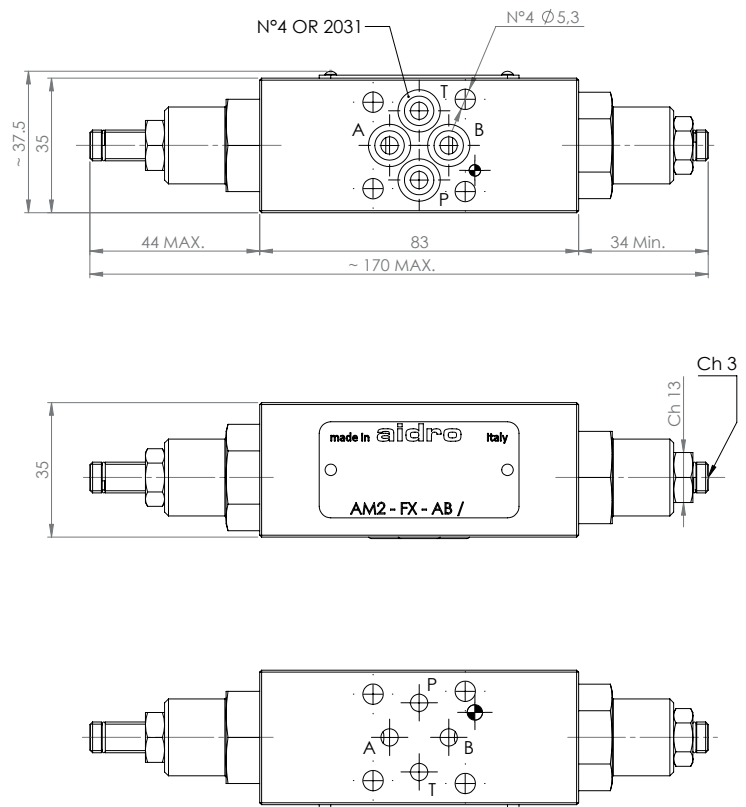

6 HYDRAULIC FLUIDS

Seals and materials used on standard valves AM2-* are fully compatible with hydraulic fluids of mineral oil base, upgraded with antifoaming and antioxidizing agents. The hydraulic fluid must be kept clean and filtered to ISO 4406 class 19/17/14, or better, and used in a recommended viscosity range from 10 cSt to 60 cSt.

All stackable valves AM2-FX-* conform with ISO and CETOP specifications for mounting surface dimensions. Valves height 35 mm. Leakage between valve and mounting surface is prevented by the positive compression on their seats of 4 seals of OR type. All valves have on their "mounting" surface a ø 4 mm cylindrical hole and are equipped on their "seals" surface by a ø 3 mm locating pin conform with ISO and CETOP norms. In case of necessity, the pin can be easily removed.