

IN LINE THROTTLE VALVE

HFC-14

20 l/min - 35 MPa (350 bar)

1 DESCRIPTION

This in line throttle valve is very useful to control the flow rate out from the ports A and B of the HDF valves. It can be easily installed and rotated in order to be easily accessible.



2 ORDERING CODE

| (1) | (2) | (3) | (4) |
|-----|-----|-----|------|
| HFC | - | 14 | / 10 |

- (1) HFC: Flow control for HDF valves
- (2) 14: size G1/4
- (3) Code reserved for options and variants
- (4) Design number (progressive) of the pump module

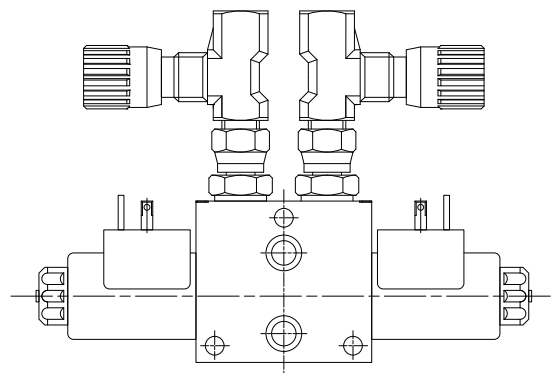
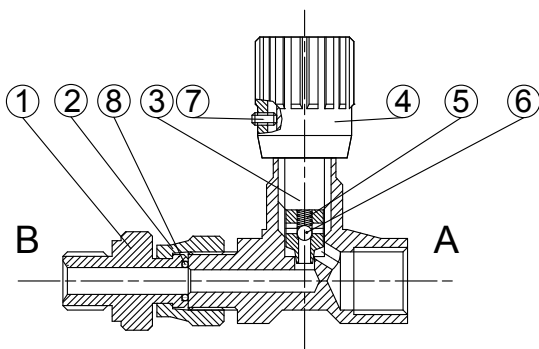

Example of HDF-ES-* with HFC-14 installed

When fluid flows from A to B the check ball 6 (kept in its position by the spring 5) closes the main passage, thus the fluid passes through the restricted annular section, which area depends on the position of the throttling spool 3. During flow from B to A the fluid shifts the check ball 6 against the spring 5 thus permitting free flow. Typically HFC-14 valves are mounted on the A and B ports of HDF-ES-*** solenoid valves; the presence of "turning joint" 2, acting on nipple 1, allows easy installation and contemporary mounting of flow valves on both A and B ports.

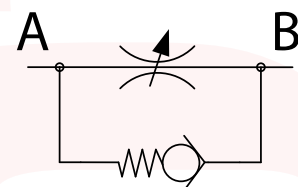

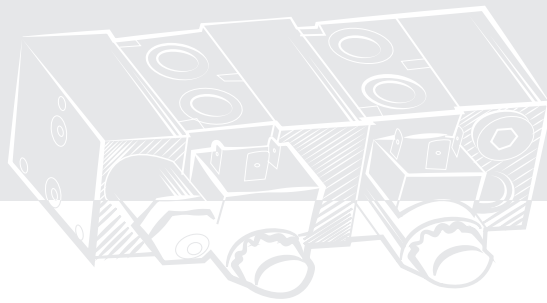

3 TECNICAL DATA

| | |
|--------------------------|------------------|
| Maximum nominal flow | 20 l/min |
| Maximum nominal pressure | 25 MPa (250 bar) |
| Mass | |

4 INSTALLATION DIMENSIONS (mm)

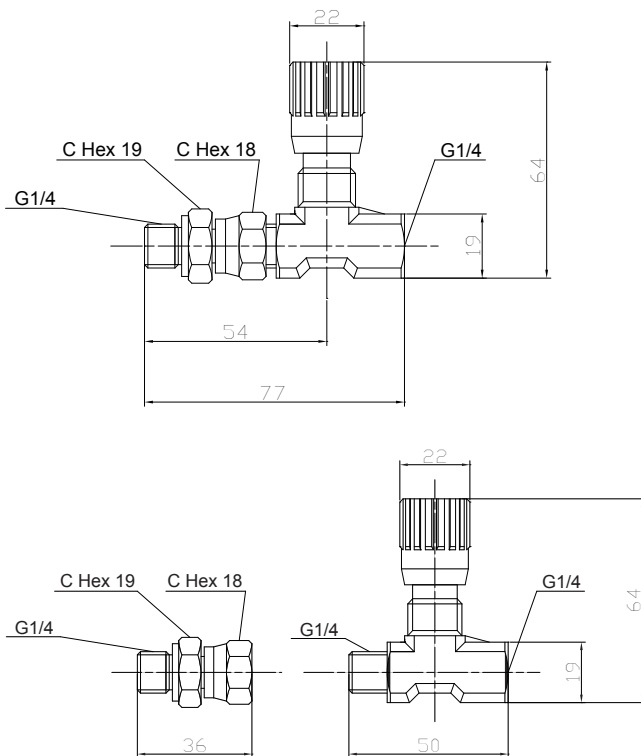

INSTALLATION

1. Lock the nipple 1 in a G1/4 port.
2. Put O-Ring 8 in its seat.
3. Fit the male thread of the valve in the turning connector.
4. While keeping the valve in the desired final orientation, screw the turning connector until blocking.

ADJUSTMENT OF THE REGULATED FLOW

To reduce the flow rate in the regulated direction (A -> B) turn clockwise knob, after having unlocked its retaining screw.

5 TYPICAL DIAGRAMS

