

## PILOT OPERATED CHECK VALVE

### AMF-CP-AB

20 l/min - 25 MPa (250 bar)

#### 1 DESCRIPTION

Pilot operated check valve to be used with HDF2-ES directional valves which have the ports A and B plugged.  
Steel body and high precision machining of the internal parts assures a long service life and an high tightness.  
The standard coating is the phosphate coating. On demand it is possible to have the zinc coating for an higher protection degree.

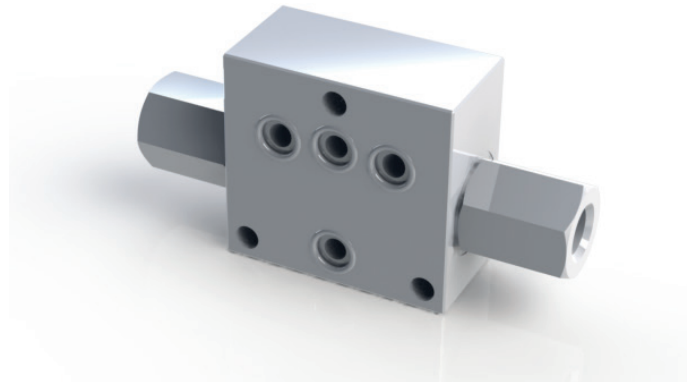

#### 2 ORDERING CODE

(1)	(2)	(3)	(4)	(5)	(6)
AMF	-	CP	-	AB	/ 10

- (1) AMF: module stackable with 4 way solenoid valve type HDF2-ES (with P and T passing)
- (2) Type end of stack module:  
no designation: standard  
C: end of stack module (P and T plugged)
- (3) CP: check valve, pilot operated (hydraulically)
- (4) AB: service lines where the controls operate
- (5) Code reserved for options and variants
- (6) Design number (progressive) of the valves

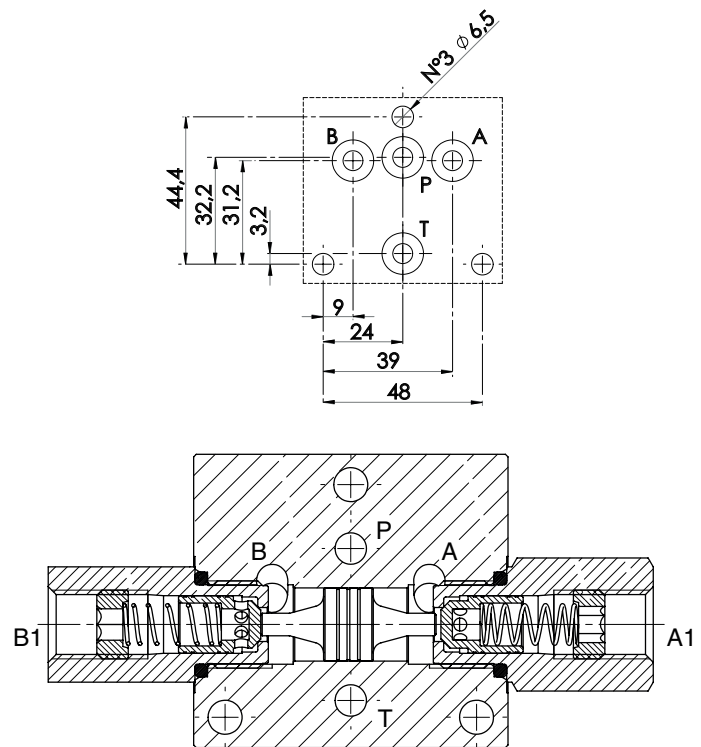

Fluid flows freely on P and T lines (AMF-CP-AB). Fluid is blocked on P and T lines (AMFC-CP-AB). On service lines A and/or B with p.o. check, fluid flows A --> A1 (and/or B --> B1) overcoming the force of spring acting on poppet and fluid is blocked A1--> A (and/or B1 --> B). When, by switching the solenoid 4-way directional valve, pressure is made available, at, for instance, port B, fluid flows B --> B1 and the pilot piston 3, shifting from its central position, forces poppet 2, on service line A, to open and permit flow A1--> A.

#### AMF-CP-AB

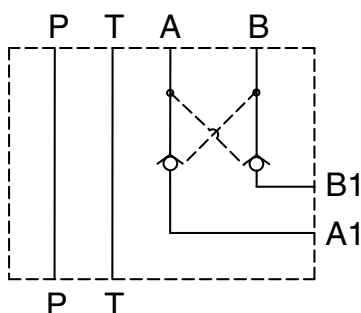

#### AMFC-CP-AB

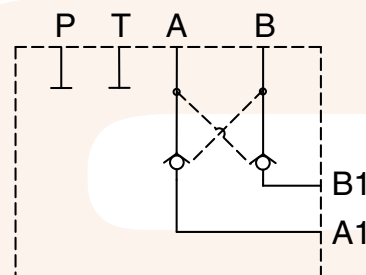

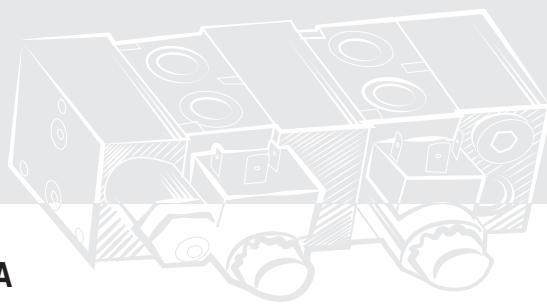

### 3 TECHNICAL DATA

Maximum nominal flow	20 l/min	Pilot area ratio piston/check valve	approx 4.7
Maximum rec. flow rate	25 l/min	Piloting pressure	To shift the pilot piston and to open the check in A the piloting pressure must be, at B:
Maximum nominal pressure	25 MPa (250 bar)		$P_p = P_b = \frac{P_{a1} + P_m \cdot P_a}{4.7}$
Material	Steel body		Were: $P_p$ = Piloting pressure
Surface protection	Phospate coating		$P_b$ = Pressure in B
Duty cycle	100%		$P_a$ = Pressure in A
Service life	10 <sup>7</sup>		$P_{a1}$ = Pressure in A1
Dimensions and Installation	see 4		$P_m$ = Check valve opening pressure (spring)
Mass	0,81kg	Cracking Pressure	1 bar

### 4 INSTALLATION DIMENSIONS (mm)

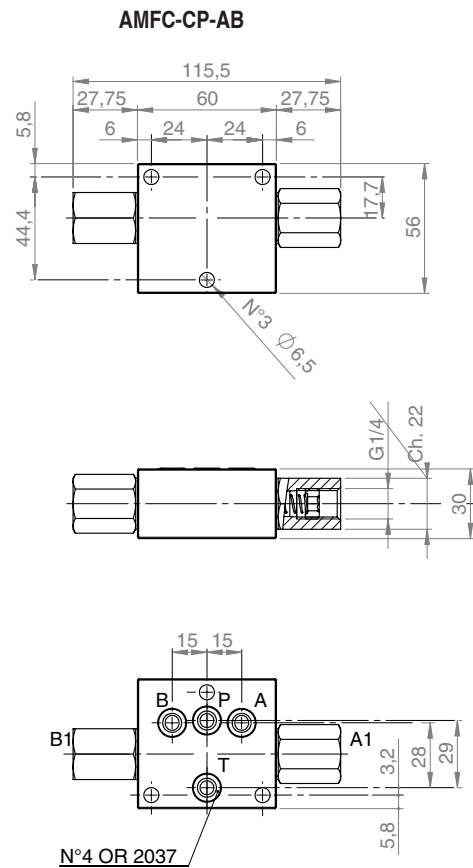
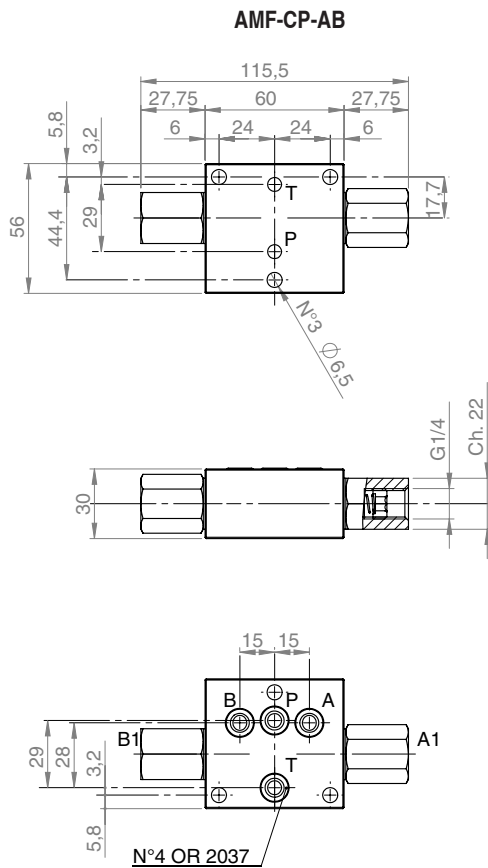

### 5 HYDRAULIC FLUIDS

Seals and materials used on standard valves AMF are fully compatible with hydraulic fluids of mineral oil base, upgraded with antifoaming and antioxidizing agents.

The hydraulic fluid must be kept clean and filtered to ISO 4406 class 21/18/15, or better, and used in a recommended viscosity range from 10 cSt to 60 cSt.

### 6 OPTIONS

Available for P and T lines "section reducer" or "stop" with O ring

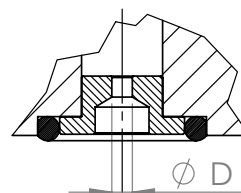

D (mm)	CODE
1,0	3S-10
1,5	3S-15
2,0	3S-20
2,5	3S-25