

PRESSURE COMPENSATED FLOW CONTROL VALVES

AM3-Q3-P

40 l/min - 32 MPa (320 bar)

1 DESCRIPTION

3 way pressure compensated flow control valves are designed to provide adjustable controlled flow rates independent of changes in system pressure.



2 ORDERING CODE

(1)	(2)	(3)	(4)	(5)	(6)
AM3	-	Q3	-	P	/ 16 - / 10

(1) AM3: stackable valve CETOP 03 - Pressure 32 MPa (320 bar)

(2) Q3: 3-way pressure compensated flow control valves

(3) P: Service lines where the controls operate

(4) Flow control characteristics:

16=0,06-> 16l/min max regulated flow control rate to P1.

When the inlet flow (at P2) is more than the regulated value, the excess is discharged at T line

(5) Code reserved for more options and variants

(6) Design number (progressive) of the valves

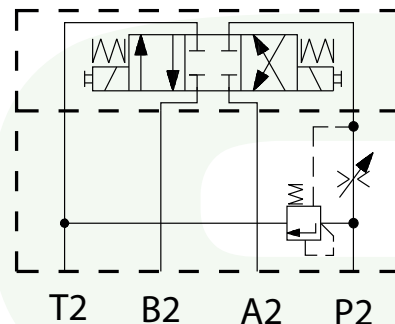
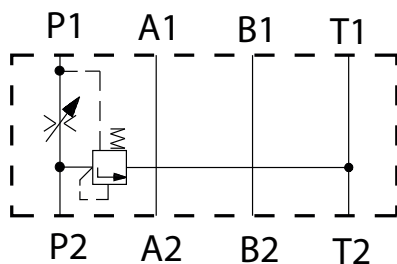
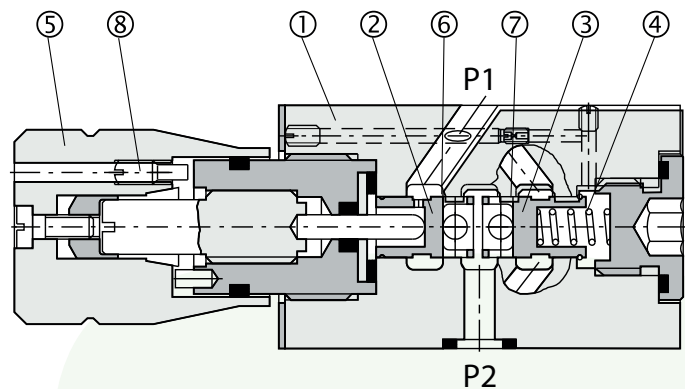
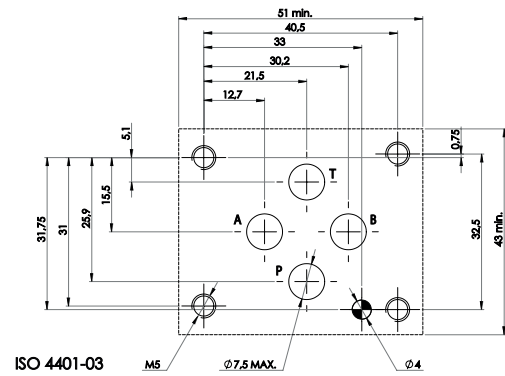

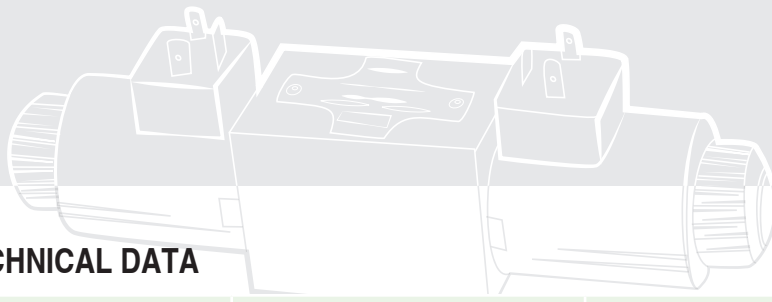

3 TECHNICAL DATA

Maximum rec. flow rate	40 l/min	Control of the flow: By turning the knob 5, the value of the regulated flow changes. The scale/flow characteristic is approx linear and the full range is covered by turning the knob by approx 320°. The scale is divided in 10 marks. Clockwise: flow increases Anticlockwise: flow decreases When the required value is reached, set the knob position by fixing screw 8.
Maximum flow rate on P1 port	16 l/min	
Maximum nominal pressure	32 MPa (320 bar)	
Flow curves	see 4	
Installation and dimensions	see 6	
Mass	approx 0,8 kg	

4 TYPICAL DIAGRAMS

Typical adjustment curves (Q-marcks and Q-P) for valves AM3-Q3-P in standard configuration

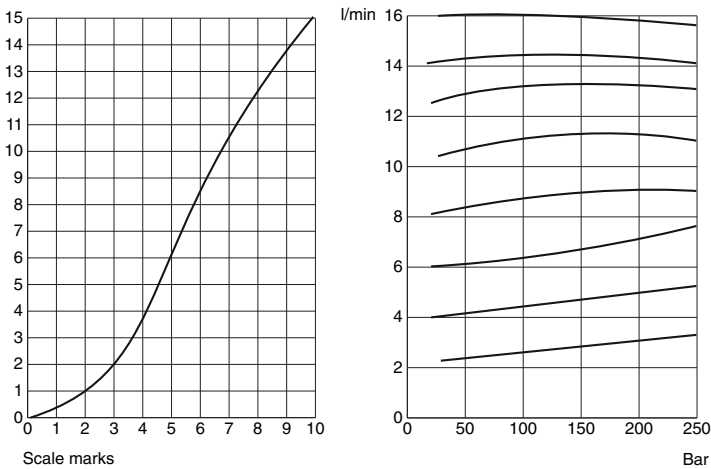

5 HYDRAULIC FLUIDS

Seals and materials used on standard valve AM3-* are fully compatible with hydraulic fluids of mineral oil base, upgraded with antifoaming and antioxidantizing agents. The hydraulic fluid must be kept clean and filtered to ISO 4406 class 19/17/14, or better, and used in a recommended viscosity range from 10 cSt to 60 cSt.

6 INSTALLATION DIMENSIONS (mm)

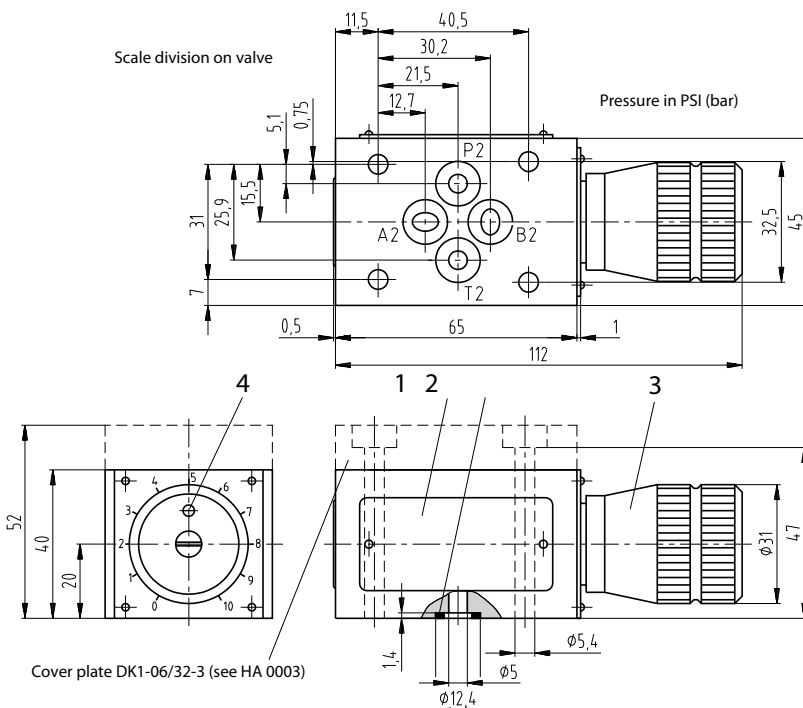

All stackable valves AM3-Q3-* conform with ISO and CETOP specifications for mounting surface dimensions and for valves height 40 mm. Leakage between valve and mounting surface is prevented by the positive compression on their seats of 4 seals type OR 2037.