

Directional control valves solenoid operated - Cetop 02 type HD2 - ES - *

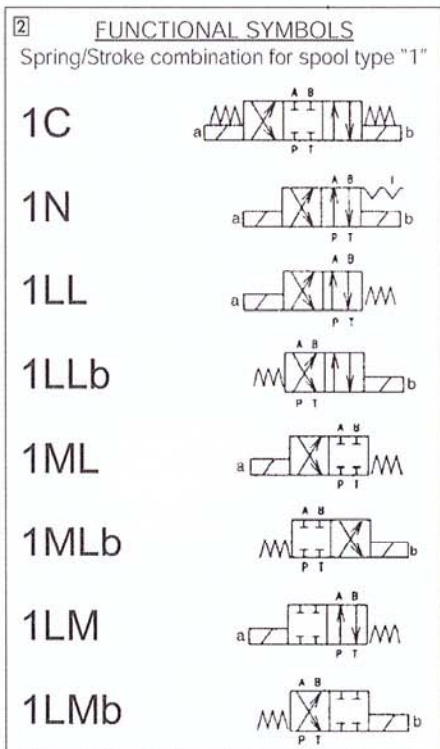

- 1 HOW TO READ THE MODEL CODE FOR VALVES HD2 - ***
- HD2 - ES - (1) (C) - * - (024C) / 11
 ① ② ③ ④ ⑤ ⑥ ⑦
- ① HD2 : 4-way directional control valve Cetop 02 - Pressure 32 MPa (320 bar)
 - ② ES : electrically controlled, standard
 - ③ (1) : spool type (see 2)
 - ④ (C) : solenoid(s) and spring(s) arrangement, see also functional symbols 2
 - C : 2 sol., spool is spring centered (3 position)
 - N : 2 sol., spool is detented (2 position)
 - LL : 1 sol. (a), spool is spring offset (2 position, end to end)
 - ML : 1 sol. (a), spool is spring offset (2 position, middle to end)
 - LM : 1 sol. (a), spool is spring offset (2 position, end to middle)
 - ⑤ * : Code reserved for option and variants
 - b : only for version LL, ML, LM
 - sol. b installed (instead of sol. a)
 - K : protruding emergency pins, protected by rubber caps (see 13)
 - S* : calibrated orifice on P port (see 14)
 - ZC : zinc plated valve, see 16
 - ⑥ (024C) : Electric voltage and standard solenoid coils
 - 0000 : no coil (s)
 - 012C : coil (s) for V12DC
 - 024C : coil (s) for V24DC
 - 115A : coil (s) for V110/50 - V 115/60 AC
 - 230A : coil (s) for V220/50 - V 230/60 AC
 See also electric characteristics 6
 AMP : solenoid coils with electric terminals according to AMP-Timer (see 15)
 - ⑦ Design number (progressive) of the valves

3 DESCRIPTION
The spool 12 shifts in to the valves body 11 subject to the action of springs 13 and solenoids 1. Spool 12, depending from its shape and its position in the valves body 11, opens and/or closes passages between P, A, B, T ports, thus controlling the direction of the hydraulic flow. Solenoids 1 and 2 are energized by electric current flowing-in through connectors 3 and 4; in case of electric cut-offs, the spool can be manually shifted by acting on the emergency pins 5, located at the end of the solenoids and accessible through the retaining nuts 10.

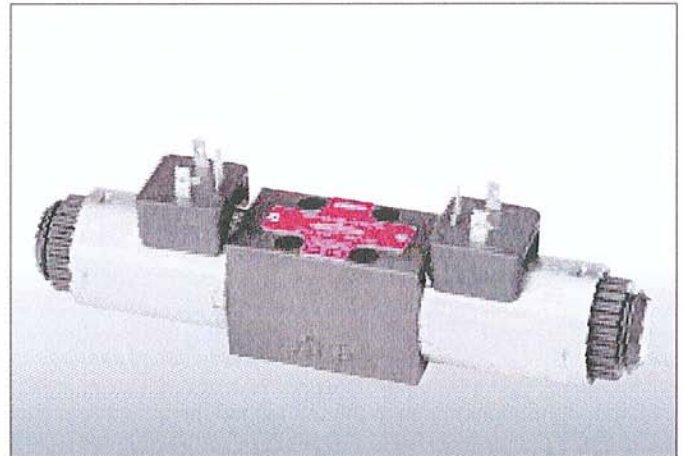
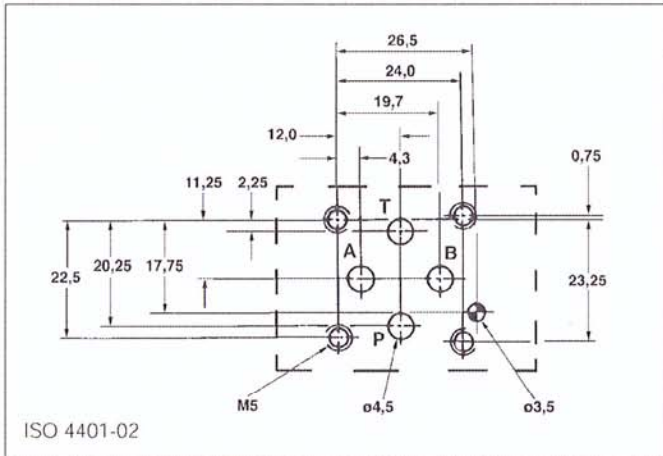
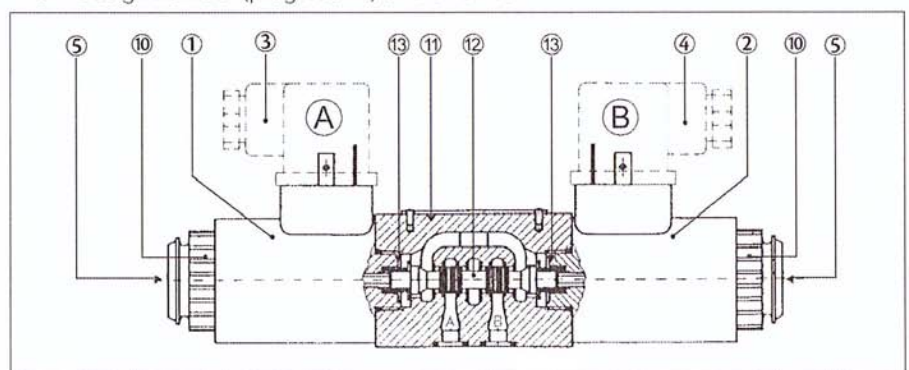

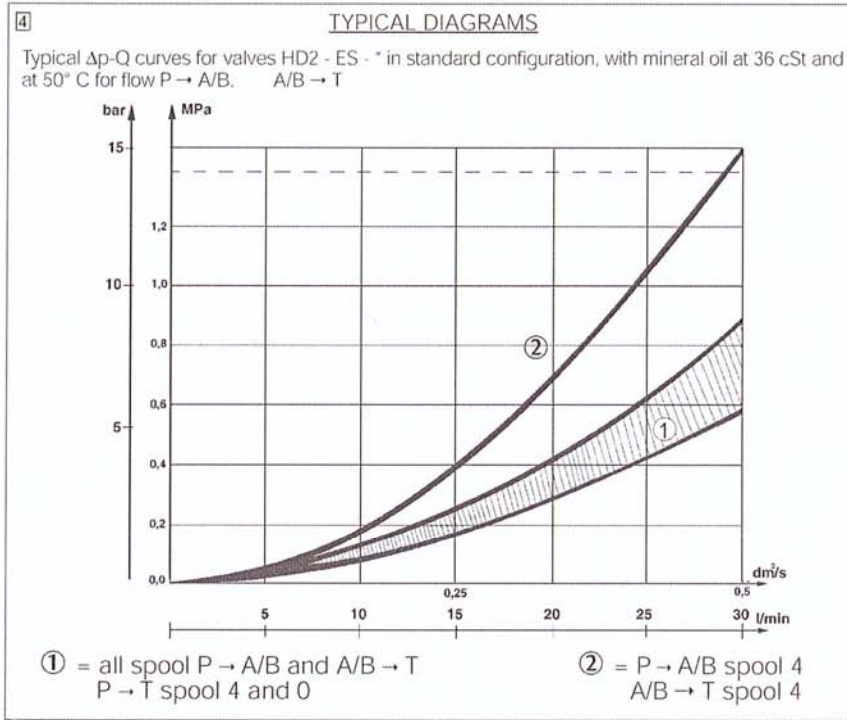

5 TECHNICAL DATA

maximum nominal flow	0,5 dm ³ /s (30 l/min)
maximum rec. flow rate	see 9
maximum nominal pressure (P,A,B,)	32 MPa (320 bar)
maximum pressure at T port	16 Mpa (160 bar)
pressure drops	see 4
electric characteristics	see 6
protection to DIN 40050	IP 65
duty cycle	100%
service life	≥ 10 ⁷ cycles
dimensions	see 10
installation	see 11
mass	approx 1,0/1,4 kg

7 SPOOL IDENTIFICATION AND INTERMEDIATE POSITION TRANSITORIES

OC		OLL	
1C		1LL	
3C		1LLb	
4C		2LL	
55C		OML	
7C		1ML	
8C		3ML	
1N		4ML	
2N		8ML	

6 ELECTRIC CHARACTERISTICS

Valves type HD2-ES-* are operated by solenoid that are energized:

- directly from a D.C. voltage supply:
V 12 DC = 012 C
V 24 DC = 024 C
- by the use of coils that incorporate a full wave bridge rectifier, from A.C. voltage supply:
V 110/50 (V 115/60) = 115 A
V 220/50 (V 230/60) = 230 A

All standard valves are to be fitted with connectors conform to ISO 4400 (DIN 43650) and electric circuitry must be able to carry the following rated current values:

- V 12 DC = 2,4 A
- V 24 DC = 1,2 A
- V 110/50 = 0,30 A
- V 220/50 = 0,15 A

Permissible supply voltage variation:
+5% -10%

8 FUNCTIONAL SYMBOLS

Spools, springs and solenoids combination permit to obtain almost every type of ports (P, A, B, T) connection and sequence.

For almost all types of solenoids/springs combination and for all type of spools (with the exception of spool 4), when solenoid "a" is energized, hydraulic connections are P → B and A → T; to obtain P → A and B → T solenoid "b" must be energized.

The hydraulic connections that are obtained in the "central" (neutral) position when solenoids are not energized is the characteristic mark of the spool shape and from it derives its identification number:

- 0 = P, A, B, T connected
 - 1 = P, A, B, T closed
 - 3 = P closed, A, B, T, connected
- for other types see 7.

9 HYDRAULIC LIMITS OF USE

P/Q characteristic limits for safe use of HD2-ES-* solenoid operated valves.
Limit curves apply to sol. valves energized with rated voltage - 5% and flushed with hydraulic fluid with properties according to 12.

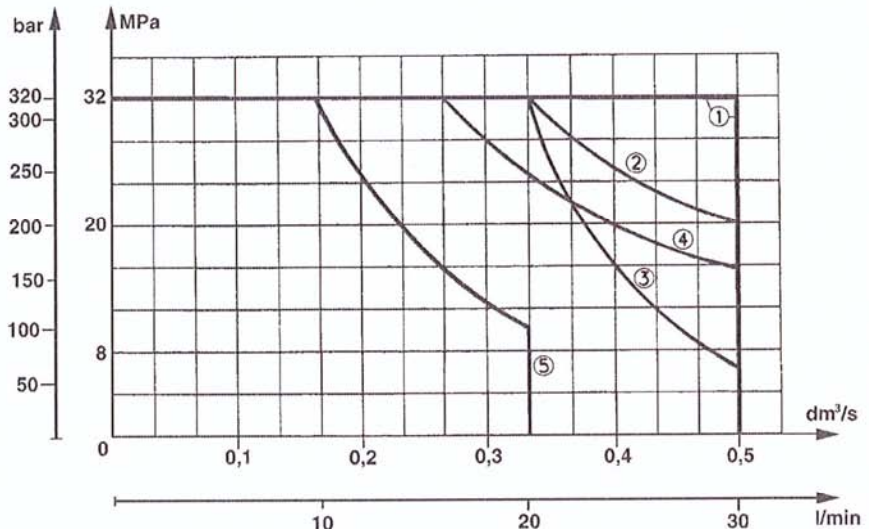

- ① = HD2 - ES - 0C; - 1C; - 1N; - 3C; - 8C; - 0ML; - 1LL; - 1ML; - 3ML; - 8ML
- ② = HD2 - ES - 2N; - 7C
- ③ = HD2 - ES - 0LL
- ④ = HD2 - ES - 4C; - 4ML
- ⑤ = HD2 - ES - 55C; - 2LL

11 INSTALLATION

All valves HD2 - * conform with ISO and CETOP specifications for mounting surface dimensions (see also front page) and for valves height. When assembled to its mounting plate valve HD2 - * must be fastened with 4 bolts M5 x 35 mm (or M5 x ** according to the number of modules) tightened at 8 Nm torque.

Leakage between valve and mounting surface is prevented by the positive compression on their seats of 4 seals of QUAD/O Ring type 7,65x1,68x1,68.

Solenoid valves can be supplied without electric coils, as HD2 - ES - ** - 0000 -. Coils are supplied separately; standard, 3 electric pins, coils are BO2 - 012 C, BO2 - 024 C, BO2 - 115 A and BO2 - 230 A. Connections to the electric supply is made:

- a) on standard solenoid coils by standard 3-PIN connectors, according to ISO 4400 (DIN 43650). Connectors can be with different cable exit size (PG9, PG11) and beside of the plain connecting function they may incorporate various features like - signal led - voltage surge suppressor, etc.

- b) on type "AMP" solenoid coils, by connectors conforming to AMP-Timer (see 15).

12 HYDRAULIC FLUIDS

Seals and materials used on standard valves HD2 - * are fully compatible with hydraulic fluids of mineral oil base, upgraded with antifoaming and antioxidizing agents.

The hydraulic fluid must be kept clean and filtered to ISO 4406 class 19/17/14, or better, and used in a recommended viscosity range from 10 cSt to 60 cSt.

10 INSTALLATION DIMENSIONS

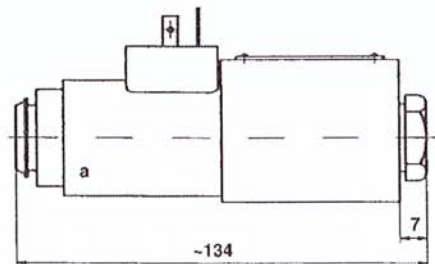
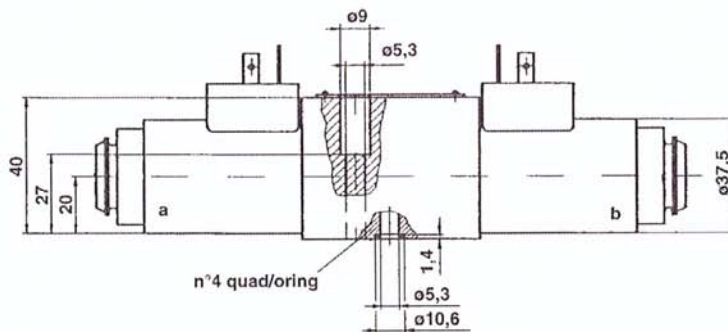
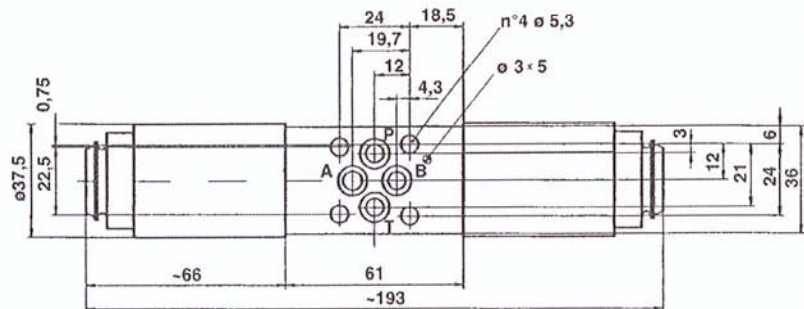

All dimensions are mm

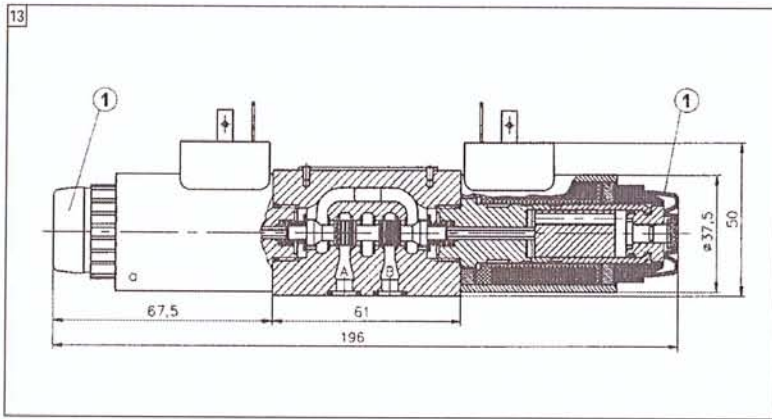

13 VERSION "K":
EXTENDED EMERGENCY PIN

Solenoid valves according to "K" version have extended emergency actuator pins protruding from the solenoid shape, that permit a quick and easy "hand operation" of the valves, without the need of any tool. The actuator pin and the end of the solenoid are protected by a flexible rubber cap ① that makes easy operation and protects from moisture and water splashes.

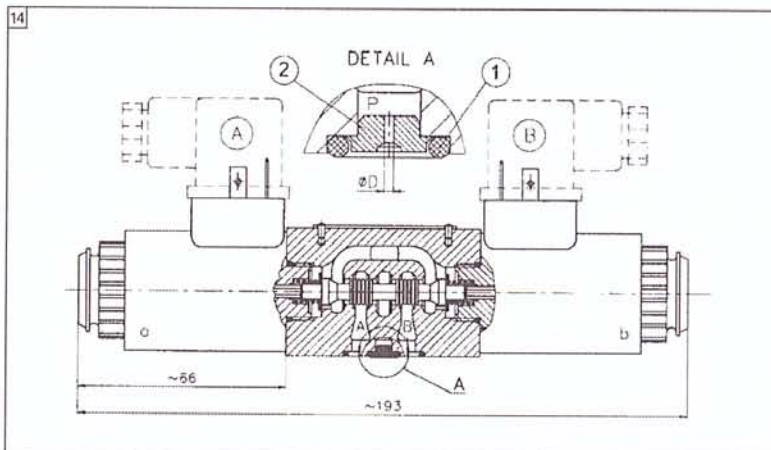

14 VERSION "S*":
CALIBRATED ORIFICE ON P PORT

Option "S*" is represented by elements ②, suitably shaped to be inserted on P port of the solenoid valve, having a calibrated orifice (of various sizes) able to restrict, at the requested ΔP value, the flow rate entering the solenoid valve.

Those elements have the following orifice diameter:

2S - 08 $\rightarrow D = 0.8$ mm

2S - 10 $\rightarrow D = 1$ mm

2S - 12 $\rightarrow D = 1.2$ mm

2S - 15 $\rightarrow D = 1.5$ mm

and are kept sealed on the P port of the valve by an OR ① of 7.65x1.78 mm sizes (example OR 107-2031).

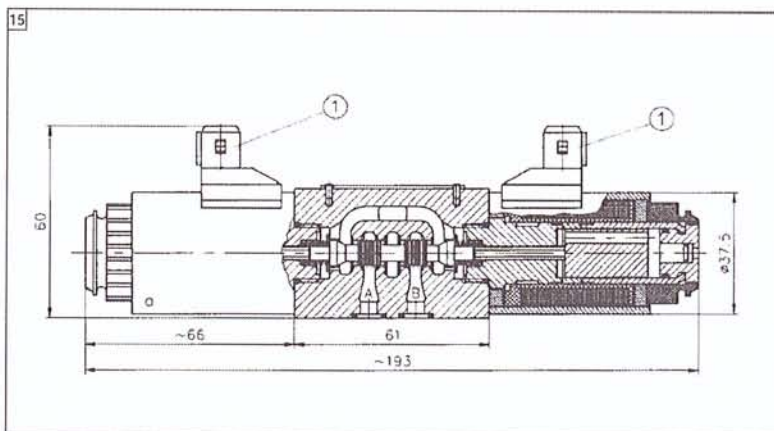

15 VERSION "AMP":
SOLENOID COILS WITH AMP-TIMER PINS

Coils of this type have 2 electric pins ① conforming for AMP-Timer connectors.

They are typically used on DC mobile application and they are available for the following voltages:

B02 - 012 C AMP = V 12 DC

B02 - 024 C AMP = V 24 DC

B02 - 027 C AMP = V 27 DC

B02 - 048 C AMP = V 48 DC

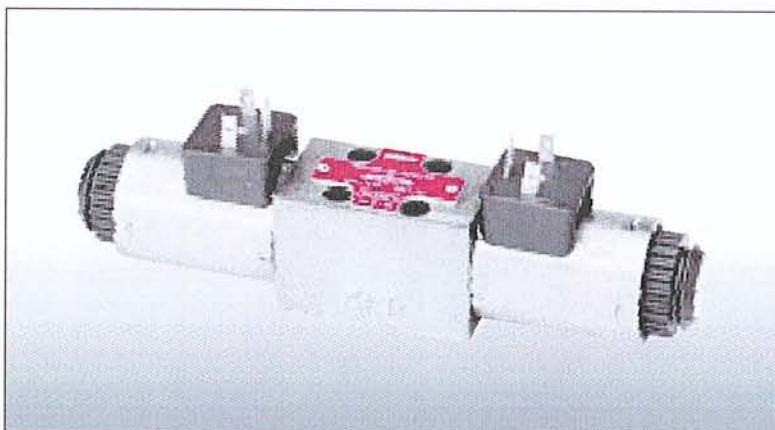

16 VERSION "ZC":
ZINC PLATED VALVES

Solenoid valves according to "ZC" version are completely zinc plated and protected against every type of corrosion due to saline ambiance or other aggressive chemicals.

Zinc thickness are:

on the valve body 10-15 μm ;

on the solenoid tubes 8-12 μm ;

on the solenoid coils 8-12 μm .